

## CML Electronics Limited

### Using Digitrax BD-4 Block Detector with the SIGM10 Signal Controller

The SIGM10 Automatic Signal Controller needs to know where the trains are to be able to operate correctly. This can be provided using any LocoNet interfaced block detector. Using this approach, train positions are reported using sensor report messages on LocoNet, and these messages can be decoded to determine which track sections are occupied. Sensor messages can be generated from, among others, the following combinations:

- Digitrax BDL168 block detector units.
- CML Electronics DAC10 accessory decoders, with block detectors attached to its inputs.
- Digitrax DS64 accessory decoders, with block detectors attached to its inputs.
- The SIGM10 itself, with block detectors attached to its inputs.

The SIGM10 has 8 sensor inputs that can be connected via SK3. These input can be connected to detectors from many sources. Digitrax supply a four input block detector, the DB-4, that works well with the SIGM10. Up to two BD-4 units can be connected to provide 8 block detect sections.

#### Connecting the BD-4

The BD4 outputs are connected using its plug DS-1. This connects to the SIGM10 SK3. Unfortunately the ribbon cables cannot be connected directly, but can be wired using a small terminal strip. Connections are shown for up to 2 BD-4 units, providing a total of 8 block detection zones.

SIGM10	1 <sup>st</sup> BD4	2 <sup>nd</sup> BD4
1	1	
3	3	
5	5	
7	7	
SK2 pin 2	2, 4, 6 or 8	
9		1
11		3
13		5
15		7
SK2 pin 2		2, 4, 6 or 8

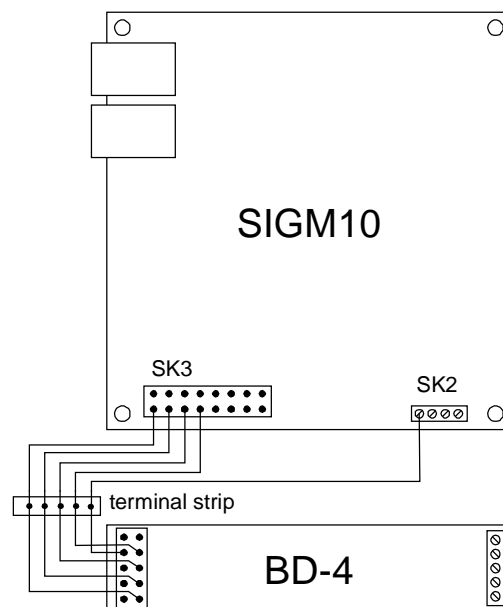

## Programming the SIGM10

The SIGM10 inputs need to be selected to generate sensor messages. The settings are normally programmed using the Locoanalyse application for a PC.

The sensor information is programmed using the SIGM10 editing form:

Form item	Programming
Sensor Board Number	Choose a number between 1 and 255. This must be different from the number assigned to any BDL168 or SE8c boards.
Sensor 1&2 Configuration	Sets how inputs 1&2 are used. Choose “General Sensor” when connected to a BD-4
Sensor 3&4 Configuration	Sets how inputs 3&4 are used. Choose “General Sensor” when connected to a BD-4
Sensor 5&6 Configuration	Sets how inputs 5&6 are used. Choose “General Sensor” when connected to a BD-4
Sensor 7&8 Configuration	Sets how inputs 7&8 are used. Choose “General Sensor” when connected to a BD-4

## In Use

The BD-4 informs the SIGM10 when track sections are occupied. The SIGM10 reports this information to LocoNet, and uses it as part of its programming. Signals can be programmed to go red when a track section is occupied, and other effects are possible.