

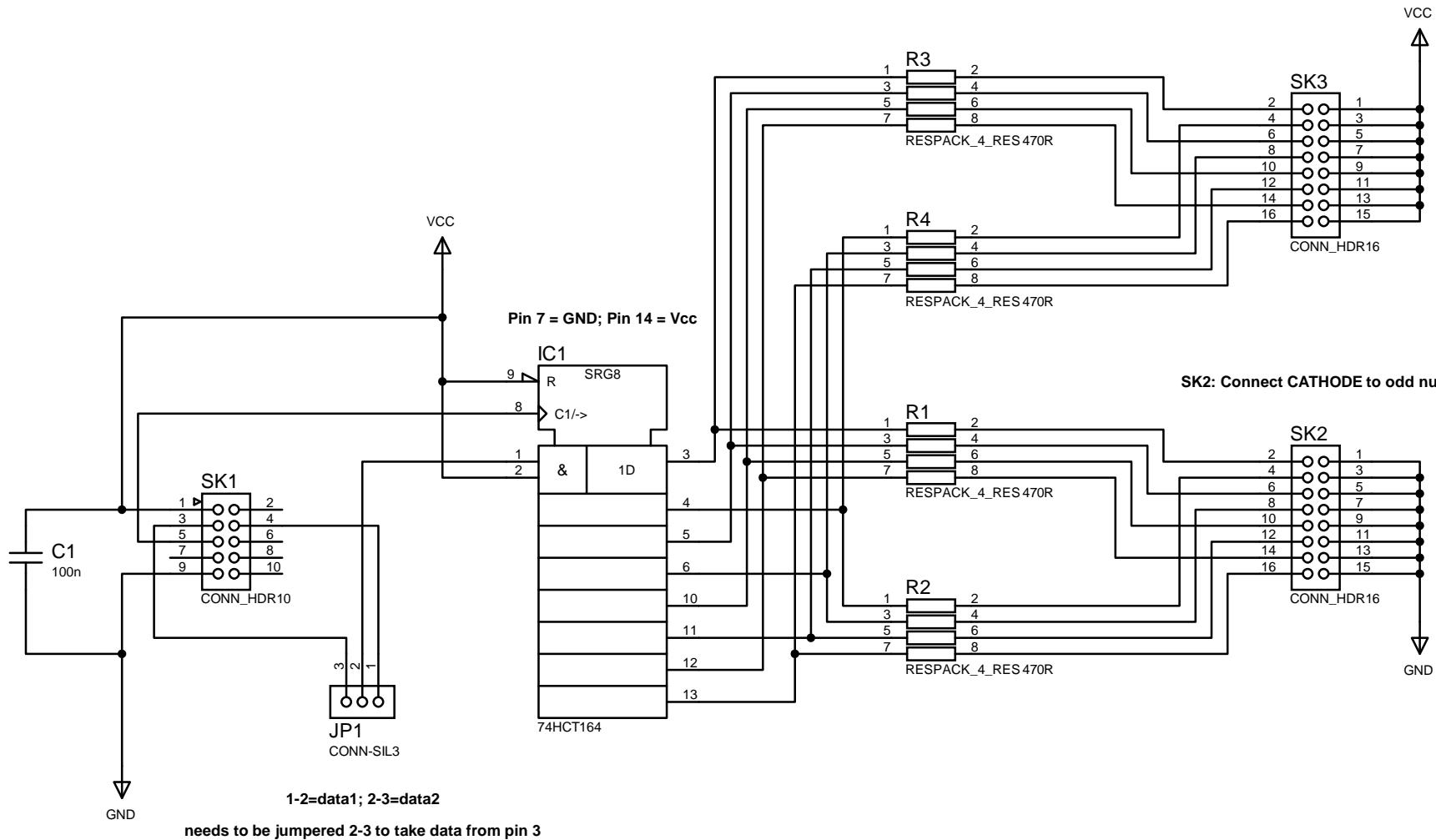

SK3: Connect ANODE to odd numbered pins



When used with DAC10:  
 Assemble all components and connectors  
 SK3 LED lit if point CLOSED;  
 SK2 LED lit if point THROWN

When used with SIGM20:  
 Do not assemble SK3, R3, R4 (these are not required)  
 Connect signals to SK2  
 pin 2/4/6/8 = signal 9 green/amber/red/aux  
 pin 10/12/14/16 = signal 10 green/amber/red/aux

	CML Electronics Limited 18 Nickleby Road Clanfield Waterlooville Hants PO8 0RH www.cmlelectronics.co.uk	TITLE: DTX8 serial to LED output REV: 1
		SHEET: 1/1
		Last Edit: 10/01/08
Filename: C:\My Documents\cml electronics\products\serial IO\DTX8 serial to LED output.DSN		